

FEATURES

- SURFACE MOUNT PACKAGE
- MONOLITHIC MOS TECHNOLOGY
- LOW COST
- HIGH VOLTAGE OPERATION—350V
- LOW QUIESCENT CURRENT—2mA
- NO SECOND BREAKDOWN
- HIGH OUTPUT CURRENT—120 mA PEAK

APPLICATIONS

- TELEPHONE RING GENERATOR
- PIEZO ELECTRIC POSITIONING
- ELECTROSTATIC TRANSDUCER & DEFLECTION
- DEFORMABLE MIRROR FOCUSING

DESCRIPTION

The PA44 is a high voltage monolithic MOSFET operational amplifier achieving performance features previously found only in hybrid designs while increasing reliability. Inputs are protected from excessive common mode and differential mode voltages. The safe operating area (SOA) has no second breakdown limitations and can be observed with all type loads by choosing an appropriate current limiting resistor. External compensation provides the user flexibility in choosing optimum gain and bandwidth for the application.

The PA44 is packaged in Apex's PSOP1 non-hermetic surface mountable dual in line package. The metal back of the package is tied to $-V_S$.

TYPICAL APPLICATION

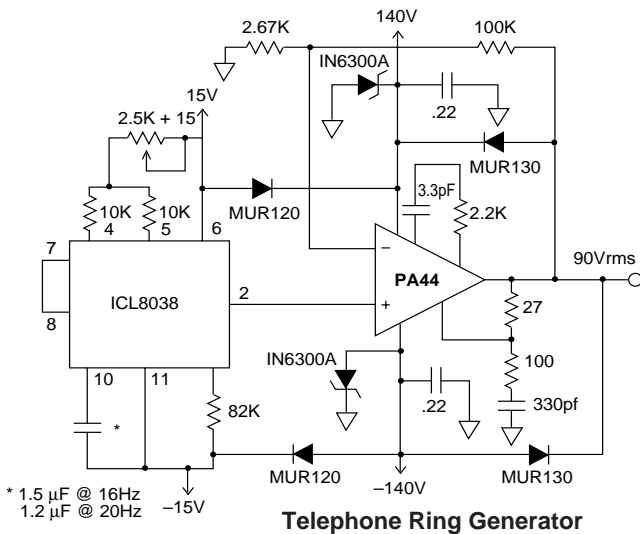

* 1.5 μ F @ 16Hz
1.2 μ F @ 20Hz

The PA44 is set for a gain of 38.5 boosting the 2.33V signal to 90V. The recommended compensation for gains above 30 is used. If capacitive loading is at least 330pF at all times, the recommended snubber network may be omitted. The 27 ohm resistor sets current limit to a nominal value of 111mA to insure peak currents out of at least 78mA.



EQUIVALENT SCHEMATIC

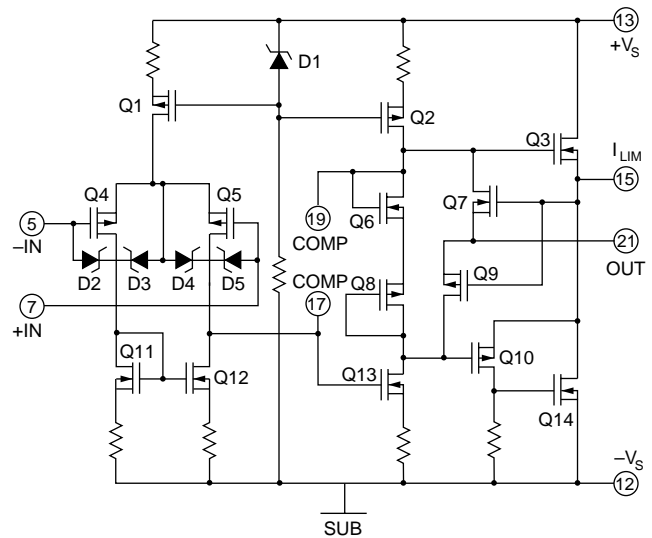

EXTERNAL CONNECTIONS

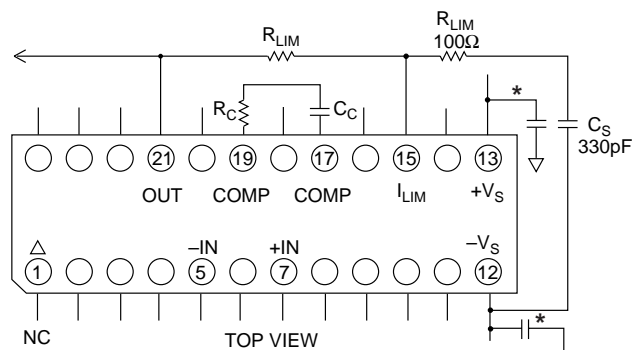

* Supply bypassing required. See General Operating Considerations.

PHASE COMPENSATION

Gain	C_c	R_c
1	18pF	2.2K Ω
≥ 10	10pF	2.2K Ω
≥ 30	3.3pF	2.2K Ω

ABSOLUTE MAXIMUM RATINGS

SUPPLY VOLTAGE, $+V_S$ to $-V_S$	350V
OUTPUT CURRENT, continuous within SOA	60 mA
OUTPUT CURRENT, peak	120 mA
POWER DISSIPATION, continuous @ $T_C = 25^\circ\text{C}$	12W
INPUT VOLTAGE, differential	$\pm 16\text{ V}$
INPUT VOLTAGE, common mode	$\pm V_S$
TEMPERATURE, pin solder – 10 sec	220°C
TEMPERATURE, junction ²	150°C
TEMPERATURE, storage	-65 to $+150^\circ\text{C}$
TEMPERATURE RANGE, powered (case)	-40 to $+125^\circ\text{C}$

SPECIFICATIONS

PARAMETER	TEST CONDITIONS ¹	PA44			UNITS
		MIN	TYP	MAX	
INPUT					
OFFSET VOLTAGE, initial ⁴	Full temperature range		15	30	mV
OFFSET VOLTAGE, vs. temperature ⁴			70	130	$\mu\text{V}/^\circ\text{C}$
OFFSET VOLTAGE, vs supply			20	32	$\mu\text{V}/\text{V}$
OFFSET VOLTAGE, vs time			75		$\mu\text{V}/\sqrt{\text{kh}}$
BIAS CURRENT, initial			50	200	pA
BIAS CURRENT, vs supply			2	20	pA/V
OFFSET CURRENT, initial			50	200	pA
INPUT IMPEDANCE, DC			10^{11}		Ω
INPUT CAPACITANCE			5		pF
COMMON MODE, voltage range			$\pm V_S - 12$		V
COMMON MODE REJECTION, DC	$V_{CM} = \pm 90\text{V DC}$	84	94	dB	
NOISE, broad band	10kHz BW, $R_S = 1\text{K}\Omega$		50	$\mu\text{V RMS}$	
NOISE, low frequency	1-10 Hz		110	$\mu\text{V p-p}$	
GAIN					
OPEN LOOP at 15Hz	$R_L = 5\text{K}\Omega$	94	106	dB	
BANDWIDTH, open loop			1.6	MHz	
POWER BANDWIDTH	$C_C = 10\text{pf}$, 280V p-p		26	kHz	
PHASE MARGIN	Full temperature range		60	$^\circ$	
OUTPUT					
VOLTAGE SWING	$I_O = 40\text{mA}$	$\pm V_S - 12$	$\pm V_S - 10$	V	
CURRENT, peak ⁵		60		mA	
CURRENT, continuous			12	mA	
SETTLING TIME to .1%	$C_C = 10\text{pF}$, 10V step, $A_V = -10$		40	μs	
SLEW RATE	$C_C = \text{OPEN}$		40	V/ μs	
CAPACITIVE LOAD	$A_V = +1$	10		nF	
RESISTANCE ⁶ , no load	$R_{CL} = 0$		150	Ω	
RESISTANCE ⁶ , 20mA load	$R_{CL} = 0$		25	Ω	
POWER SUPPLY					
VOLTAGE ³	See Note 3	± 50	± 150	± 175	V
CURRENT, quiescent			1.6	2.0	mA
THERMAL					
RESISTANCE, AC junction to case	$F > 60\text{Hz}$		6	7	$^\circ\text{C}/\text{W}$
RESISTANCE, DC junction to case	$F < 60\text{Hz}$		9	11	$^\circ\text{C}/\text{W}$
RESISTANCE, junction to air	Full temperature range		25		$^\circ\text{C}/\text{W}$
TEMPERATURE RANGE, case	Meets full range specifications	-25		$+85$	$^\circ\text{C}$

- NOTES: 1. Unless otherwise noted $T_C = 25^\circ\text{C}$, $C_C = 18\text{pF}$, $R_C = 2.2\text{K}\Omega$. DC input specifications are \pm value given. Power supply voltage is typical rating.
2. Long term operation at the maximum junction temperature will result in reduced product life. Derate internal power dissipation to achieve high MTTF.
3. Derate maximum supply voltage .5 V/ $^\circ\text{C}$ below case temperature of 25°C . No derating is needed above $T_C = 25^\circ\text{C}$.
4. Sample tested by wafer to 95%.
5. Guaranteed but not tested.
6. The selected value of R_{CL} must be added to the values given for total output resistance.

CAUTION

The PA44 is constructed from MOSFET transistors. ESD handling procedures must be observed.

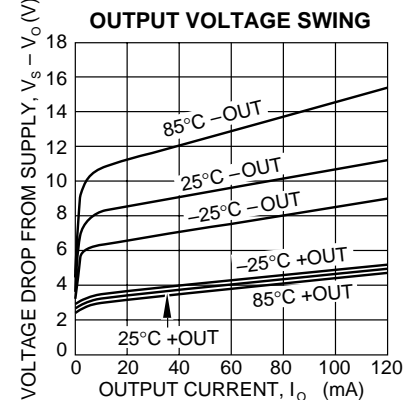
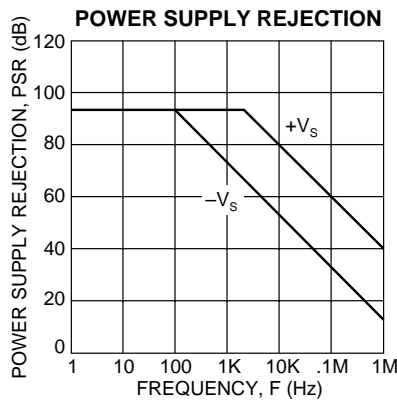
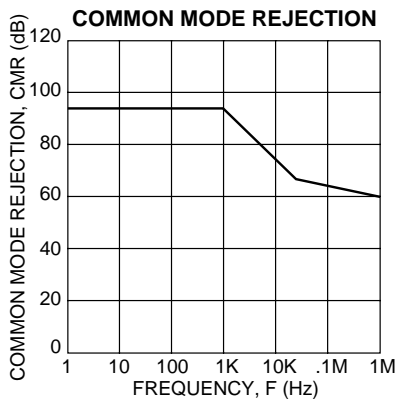
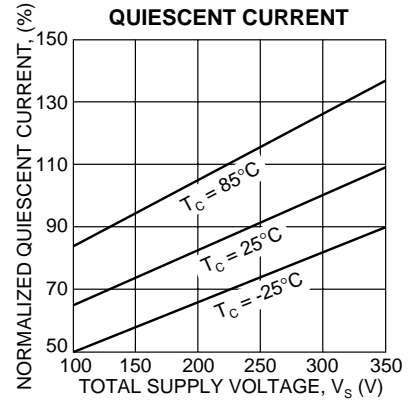
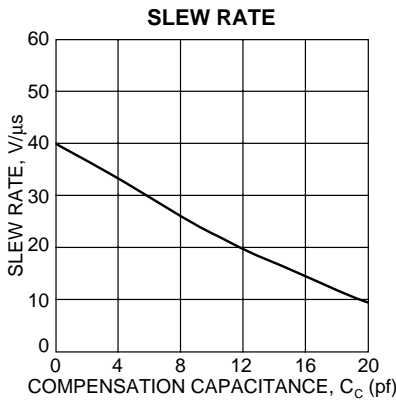
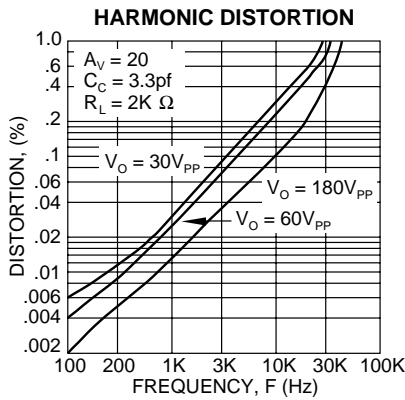
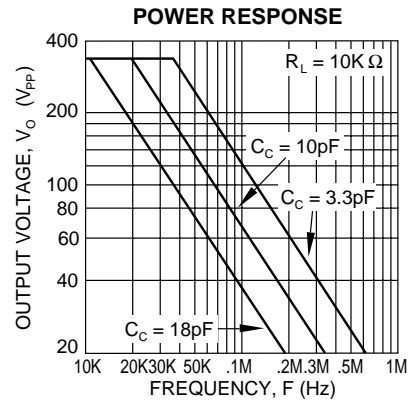
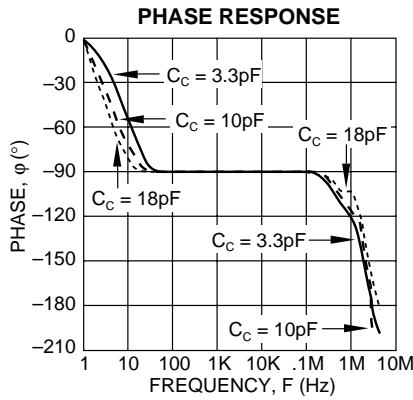
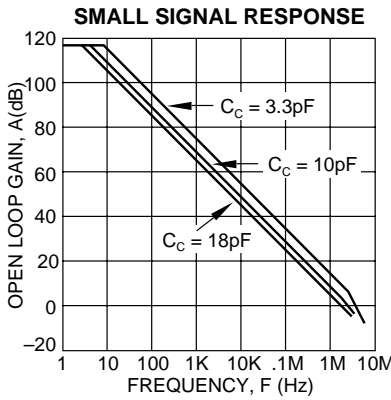
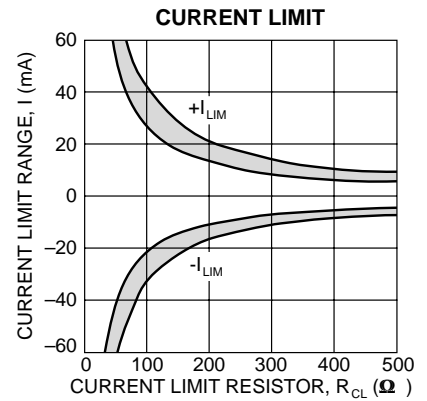
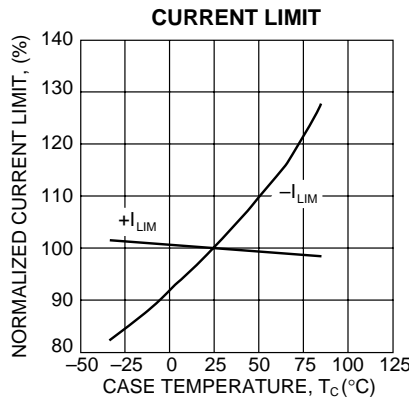
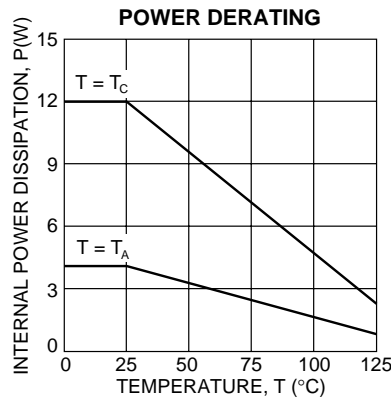

GENERAL

Please read Application Note 1 "General Operating Considerations" which covers stability, supplies, heat sinking, mounting, current limit, SOA interpretation, and specification interpretation. Visit www.apexmicrotech.com for design tools that help automate tasks such as calculations for stability, internal power dissipation, current limit; heat sink selection; Apex's complete Application Notes library; Technical Seminar Workbook; and Evaluation Kits.

CURRENT LIMIT

For proper operation the current limit resistor, R_{CL} , must be connected as shown in the external connection diagram. The minimum value is 33 ohms, however for optimum reliability the resistor value should be set as high as possible. The value can be estimated as follows with the maximum practical value of 500 ohms.

$$R_{CL} = \frac{3}{I_{LIM}}$$

Use the typical performance graphs as a guide for expected variations in current limit value with a given R_{CL} and variations over temperature. The selected value of R_{CL} must be added to the specified typical value of output resistance to calculate the total output resistance. Since the load current passes through R_{CL} the value selected also affects the output voltage swing according to:

$$V_R = I_O * R_{CL}$$

where V_R is the voltage swing reduction.

When the amplifier is current limiting, there may be small signal spurious oscillation present during the current limited portion of the negative half cycle. The frequency of the oscillation is not predictable and depends on the compensation, gain of the amplifier, and load. The oscillation will cease as the amplifier comes out of current limit.

INPUT PROTECTION

The PA44 inputs are protected against common mode voltages up the supply rails and differential voltages up to ± 16 volts as well as static discharge. Differential voltages exceeding 16 volts will be clipped by the protection circuitry. However, if more than a few milliamps of current is available from the overload source, the protection circuitry could be destroyed. The protection circuitry includes 300 ohm current limiting resistors at each input, but this may be insufficient for severe overloads. It may be necessary to add external resistors to the application circuit where severe overload conditions are expected. Limiting input current to 1mA will prevent damage.

STABILITY

The PA44 has sufficient phase margin when compensated for unity gain to be stable with capacitive loads of at least 10 nF. However, the low pass circuit created by the sumpoint ($-in$) capacitance and the feedback network may add phase shift and cause instabilities. As a general rule, the sumpoint load resistance (input and feedback resistors in parallel) should be 1K ohm or less at low gain settings (up to 10). Alternatively, use

a bypass capacitor across the feedback resistor. The time constant of the feedback resistor and bypass capacitor combination should match the time constant of the sumpoint resistance and sumpoint capacitance.

The PA44 is externally compensated and performance can be tailored to the application. Use the graphs of small signal gain and phase response as well as the graphs for slew rate and power response as a guide. The compensation capacitor C_C must be rated at 350V working voltage. The compensation capacitor and associated resistor R_C must be mounted closely to the amplifier pins to avoid spurious oscillation. An NPO capacitor is recommended for compensation.

SAFE OPERATING AREA (SOA)

The MOSFET output stage of this power operational amplifier has two distinct limitations:

1. The current handling capability of the die metallization.
2. The temperature of the output MOSFETs.

NOTE: The output stage is protected against transient flyback. However, for protection against sustained, high energy flyback, external fast-recovery diodes should be used.

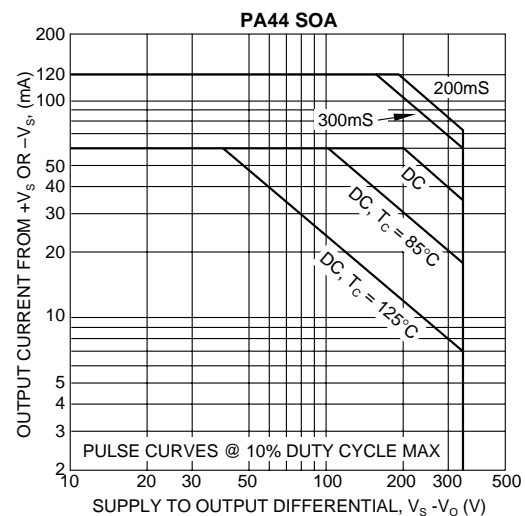

HEATSINKING

The PA44 package has a large exposed integrated copper heatslug to which the monolithic amplifier is directly attached. The solder connection of the heatslug to a minimum 1 square inch foil area of the printed circuit board will result in thermal performance of 25°C/W junction to air rating of the PA44. Solder connection to an area of 1 to 2 square inches of foil is recommended. This may be adequate heatsinking but the large number of variables involved suggest temperature measurements be made on the top of the package. Do not allow the temperature to exceed 85°C . The heatslug is tied internally to $-V_s$.